

# Lifting Capacities

Lattice Boom Crawler Crane

## 218 HYLAB 5 110-ton \* (99.8 metric ton)

### Tube Boom Capacities 40'–230' (12.19–70.10m)

#### 26' (7.92m) Live Mast Capacities

- Extended / Retracted Side Frames
- On Carbody Jacks

#### Quick Draw Capacities

- Extended / Retracted Side Frames
- On Carbody Jacks

#### 5' (1.52m) Tip Extension Capacities

#### Duty Cycle Capacities

- 40'–80' (12.19–24.38m) Tube Boom
- Extended Side Frames
- Dragline
- Clamshell / Magnet
- "A" Counterweight

#### Tube Boom Capacities

- 40' – 230' (12.19–70.10) Tube Boom
- 60" (1.52m) Wide x 50" (1.55m) Deep Boom
- 20' (6.10m) Open Throat Top Section
- With 26' (7.92m) Live Mast
- Extended / Retracted Side Frames
- 360° Capacities
- Over End Blocked Capacities
- "AB", "A", or "O" Counterweight Options
- 20' 10.5" (6.36m) Crawler Length

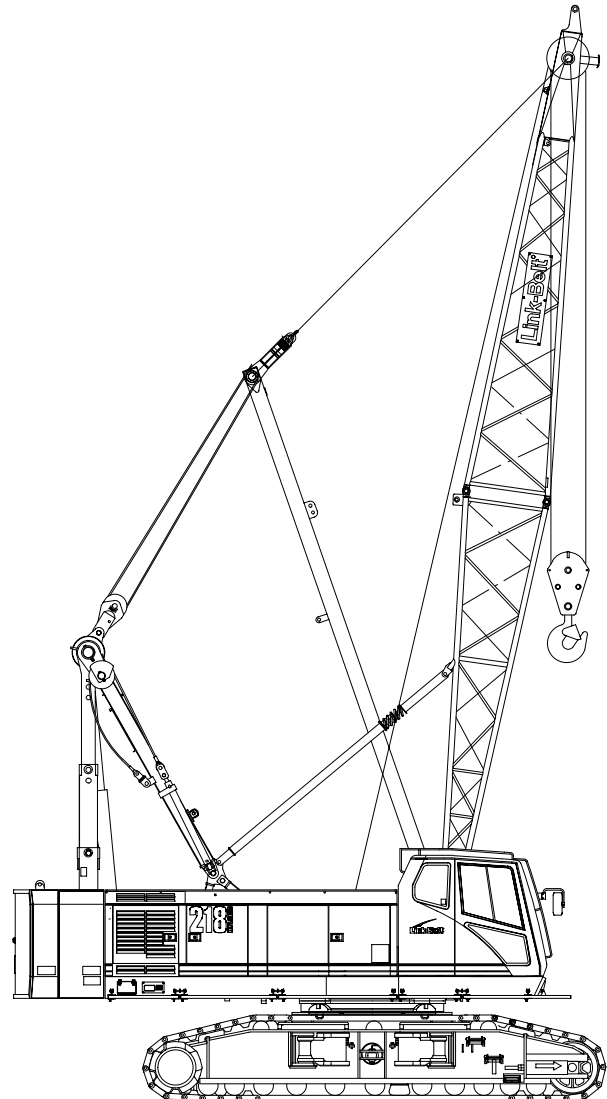

\* Nominal capacity rating may vary based on specification. Tube boom capacity with 4 sheave head machinery is 110-ton (99.8mt). Tube boom capacity with optional 3 sheave head machinery and "CASAR™" rope is 100-ton (90.7mt).

**CAUTION: This material is supplied for reference use only. Operator must refer to in-cab Crane Rating Manual to determine allowable crane lifting capacities and operating procedures.**



## WARNING

**READ AND UNDERSTAND THE OPERATOR'S AND SAFETY MANUALS AND THE FOLLOWING INSTRUCTIONS AND CHART VALUES BEFORE OPERATING THE CRANE. OPERATION WHICH DOES NOT FOLLOW THESE INSTRUCTIONS MAY RESULT IN AN ACCIDENT.**

### LIFTING NOTES

#### GENERAL:

1. Rated lifting capacities in pounds as shown on lift charts pertain to this crane as originally manufactured and normally equipped. Modifications to the crane or use of optional equipment other than that specified can result in a reduction of capacity.
2. Construction equipment can be dangerous if improperly operated or maintained. Operation and maintenance of this crane must be in compliance with the information in the Operator's, Parts, and Safety Manuals supplied with this crane. If these manuals are missing, order replacements through the distributor.
3. The operator and other personnel associated with this crane shall read and fully understand the latest applicable American National Standards Institute (ANSI) safety standards for cranes.
4. All capacities listed in this book are in compliance with ASME/ANSI B30.5 at date of manufacture.
6. The capacities listed in the Crane Rating Manual are for the crane equipped with live mast and with the gantry in the raised position.
7. The least stable rated condition is over the side.
8. Booms should be erected and lowered over the end for maximum stability. See Liftoff Capabilities before erecting or lowering boom.
9. Do not operate at radii and boom lengths where the Crane Rating Manual lists no capacity. Do not use longer booms or jibs than those listed in the Crane Rating Manual. Any of the above can cause a tipping condition, or boom and jib failure.
10. These capacities apply only to the crane as originally manufactured and normally equipped by Link-Belt Construction Equipment Company.

#### LIFT CRANE OPERATION:

1. Capacities shown are in pounds and are not more than 75% of the tipping loads with the crane standing level on firm supporting surface. A deduction must be made from these capacities for weight of hook block, hook ball, sling, grapple, etc. When using main hook while jib is attached, reduce capacities by values shown on Capacity Deductions For Lifting Off Main Boom Hook With Jib Installed. When using main hook while 5' tip extension or pile driver lead adapter is attached, reduce capacities by values shown on Capacity Deductions For Lifting Off Main Boom Hook With 5 Foot Tip Extension or Pile Driver Lead Adapter Installed. See Operator's Manual for all limitations when raising or lowering attachment.
2. The crane capacities in the shaded areas are based on structural strength. The crane capacities in the non-shaded areas are based on stability.
3. For recommended reeving, parts of line, wire rope type, and wire rope inspection, see Wire Rope Capacity Chart, Operator's Manual, and Parts Manual. Rated lifting capacities are based on correct reeving. Deduction must be made for excessive reeving. Any reeving over minimum required (see Wire Rope Capacity Chart) is considered excessive and must be accounted for when making lifts. Use Working Range Diagram to estimate the extra feet of rope. See Wire Rope Capacity for the weight to deduct for each extra foot of wire rope before attempting to lift a load.
4. Rated lifting capacities in the Crane Rating Manual are based on freely suspended loads and make no allowances for such factors as the effect of ground conditions and operating speeds. The operator shall therefore reduce load ratings in order to take these conditions into account.
5. Rated lifting capacities do not account for the effects of wind on a suspended load or boom.

Lifting capacities should be considered acceptable for wind speeds less than 20 mph and appropriately reduced for wind speeds greater than 20 mph. (See General Wind Restrictions Guide.)

#### FOR OVER END BLOCKED CAPACITIES ONLY:

1. These capacities can be lifted over either end with the crane standing level on a firm supporting surface with adequate blocking placed under the side frame sprockets/idlers, to prevent rocking.
2. Do not travel with a load.

#### TRAVELING WITH A LOAD:

1. All 360° Rotation Capacities listed in the Crane Rating Manual are pick and carry capacities.
2. The boom must be pointing straight over one end of the crawler lower. If the load was lifted over the side, swing the load over the end and/or if the load was lifted at a long radius and the load is at or near capacity for that radius, boom up to obtain a greater lifting capacity before beginning travel.
3. Engage the swing lock and apply swing brake.
4. Travel slowly and cautiously on a firm and level supporting surface.

#### DEFINITIONS:

1. Load Radius: Horizontal distance from a projection of the axis of rotation to the supporting surface, before loading, to the center of the vertical hoist line or tackle with load applied.
2. Boom Angle: The angle between the boom base section and horizontal with freely suspended load at the rated radius.
3. Working Area: Area measured in a circular arc about the centerline of rotation as shown on the Working Area Diagram.
4. Freely Suspended Load: Load hanging free with no direct external force applied except by the hoist line.
5. Side Load: Horizontal side force applied to the lifted load either on the ground or in the air.

## WIRE ROPE CAPACITY

Parts of Line	1"			3/4"	
	Type "CC"	Type "RB"	Type "DB"	Type "DB"	Notes
1	30,760	22700	29,500	16,800	Capacities shown are in pounds and working loads must not exceed the ratings on the capacity charts in the Crane Rating Manual. Study Operator's Manual for wire rope inspection procedures, and single part of line application.
2	61,520	45,400	59,000	33,600	
3	92,280	68,100	88,500	50,400	
4	123,040	90,800	118,000	67,200	
5	153,800	113,500	147,500	84,000	
6	184,560	136,200	177,000	100,800	
7	215,320	158,900	206,500	117,600	
8	246,080	181,600	236,000	134,400	
Rope weight per foot *	2.03	2.00	1.85	1.04	
LBCE Type	Description				
DB	6 x 26 (6 x 19 Class) – Warrington Seale – Extra Improved Plow Steel – Preformed – Right Lay – Regular Lay – I.W.R.C.				
RB	19 x 19 Rotation Resistant– Extra Extra Improved Plow Steel – Preformed – Right Lay – Regular Lay. Swaged – SF = 5:1				
CC	36 x 7 Class – Non–Rotating – Extra Extra Improved Plow Steel – Right Lay – Regular Lay – S.F. = 5:1				

\* Weight to be deducted from main capacities when using extra reeving.

## LIFTOFF CAPABILITIES

Counterweight (Side Frames)	Over End (Gantry In Raised Position)	
	Maximum Boom (ft)	Maximum Boom + Jib (ft)
NO (RETRACTED)	90	N/A
NO (EXTENDED)	130	N/A
A (RETRACTED)	130	N/A
A (EXTENDED)	170	N/A
AB (EXTENDED)	230 See Note 4	190 + 75 200 + 45 See Note 4
Counterweight (Side Frames)	Over Side	
	Maximum Boom (ft)	Maximum Boom + Jib (ft)
NO (RETRACTED)	90	N/A
NO (EXTENDED)	130	N/A
A (RETRACTED)	130	N/A
A (EXTENDED)	170	N/A
AB (EXTENDED)	210	170 + 75 180 + 60

## WORKING AREAS

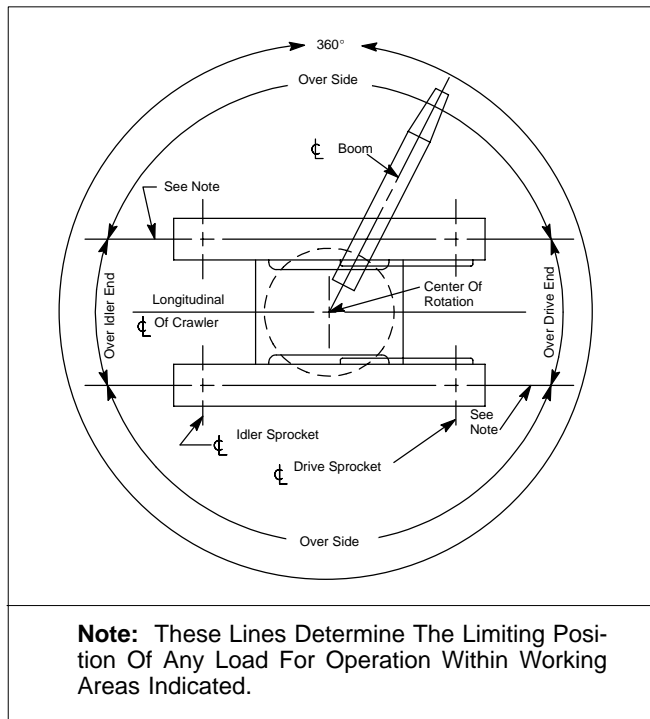

## NOTES:

1. For maximum boom and maximum boom + jib combinations only – adequate blocking must be placed under the side frame sprockets/idlers to prevent rocking. The ramps supplied with the crane are considered to be adequate blocking.
2. Crane on firm and level surface.
3. Gantry pins must be installed with the gantry in the raised position.
4. For maximum stability, booms must be erected or lowered over the end with no load and with the hook block on the ground.

## GENERAL WIND RESTRICTIONS GUIDE

**⚠ WARNING**

Failure to follow these wind speed restrictions may result in structural failure of the boom, which would cause property damage and/or bodily injury.

1. The effects of the wind force on the hook load are the responsibility of the user and are not taken into account. When hoisting any load in windy conditions, the load wind area and load controllability must be considered for safe crane operation.
2. Wind speed is to be determined at the boom top section.

## WIND SPEED CHART

Boom Lengths: 40' to 250'	
DESCRIPTION	ALLOWABLE WINDSPEEDS IN MPH
1. Normal Lifting Operation. (See Capacity Charts.)	0–20
2. Reduced Operation. <b>Capacities must be reduced by 20%.</b>	21–30
3. Reduced Operation. <b>Capacities must be reduced by 40%.</b>	31–40
4. Reduced Operation. <b>Capacities must be reduced by 70%.</b>	41–45
4. No Operation. <b>Store Attachment On Ground.</b>	Over 45

## LIVE MAST LIFTING CAPACITIES

Live Mast		Load (lb) (See Note 8)
Radius (ft)	Angle (deg)	
10	78.0	30,000
11	75.7	30,000
12	73.4	30,000
13	71.1	25,000
14	68.8	20,000
15	66.4	20,000
16	64.0	15,000
17	61.5	15,000
18	59.0	15,000
19	56.4	15,000
20	53.7	15,000
21	50.9	10,000
22	48.0	10,000
23	44.9	10,000
24	41.7	10,000
25	38.3	10,000

### NOTES:

1. Refer to the Operator's Manual.
2. Live mast backstops must be in position and operative.
3. Reeve hoist rope from rear drum with three (3) parts of 1" diameter wire rope.
4. The crane shall be leveled on a firm supporting surface.
5. All capacities are listed in pounds and are not more than 75% of the tipping loads.
6. For self-assembly of counterweights, boom extensions, and side frames only. See Crane Assembly Component Weights chart for weight of components for crane assembly.
7. Rated capacities for 360° rotation.
8. Mast capacities apply to the following conditions:

CRANE SETUP	COUNTERWEIGHTS		
	NONE	A	AB
ON CARBODY JACKS	✓	N/A	N/A
SIDE FRAMES RETRACTED	✓	✓	N/A
SIDE FRAMES EXTENDED	✓	✓	✓

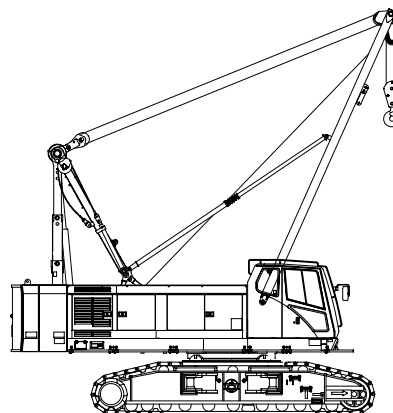

**CRANE ASSEMBLY  
COMPONENT WEIGHTS**

Component	Weight	
	lb	kg
1. 20' Top Section With Sheave Machinery	3,606	1 636
2. 20' Top Section With Sheave Machinery and 5' Tip Extension	4,246	1 926
3. 20' Base Section	1,991	903
4. Boom Extensions		
• 10' Boom Extension With Pendants	814	369
• 20' Boom Extension With Pendants	1,309	593
• 30' Boom Extension With Pendants	1,837	833
• 40' Boom Extension With Pendants	2,286	1 037
5. Upper Counterweights		
• Counterweight "A"	25,350	11 499
• Counterweight "B"	25,350	11 499
6. Side Frames (Each)	23,561	10 687
7. Tube Jib Including Strut, Head Machinery, and Pendants		
• 30' Tube Jib Assembly	1,965	891
• 15' Extension With Pendants	290	131.5

**"QUICK DRAW" SELF  
ASSEMBLY LIFTING CAPACITIES**

"Quick Draw" Cylinders		CASE I SEE NOTE 8 (lb)	CASE II SEE NOTE 9 (lb)
Radius (ft)	Boom Angle (deg)		
13.89	67	26,500	26,500
14	66.6	26,500	26,500
15	63.4	26,500	26,500
16	60	26,500	26,500
17	56.4	26,500	26,500
18	52.7	26,500	26,500
19	48.7	26,500	26,500
20	44.4	26,500	26,500
21	39.8	26,500	24,740
22	34.4	26,500	23,000
23	28.1	26,500	21,420
24	19.3	25,680	19,940

**NOTES:**

1. Rated capacities for 360° rotation.
2. Boom base section only, supported by make up pendants. No extensions or top section can be attached.
3. Lifting any load with one cylinder is prohibited. Rated capacities are for lifting loads with both cylinders.
4. Gantry must be pinned in the raised or lowered position when lifting loads with the cylinders in the base section.
5. Do not lower live mast below 3° angle with gantry in lowered position.
6. Backstops must be assembled to base section.
7. For self assembly of counterweights, boom extensions, and side frames only.
8. On extended or retracted side frames with or without counterweight.
9. On carbody jacks without counterweight.

**DUTY CYCLE NOTES FOR TUBE BOOM**

1. The capacities included in the “Duty Cycle Capacities – Tube Boom” chart are the maximum allowable, and are based on an 218 HYLAB 5 crawler crane with “A” (25,350 lb) counterweight standing level on firm supporting surface under ideal job conditions.
2. Capacities are based on 75% of minimum tipping loads for dragline; 67.5% for clamshell.
3. Capacities are maximum recommended by PCSA Standard #4. Operator must make allowances for soft or uneven supporting surfaces, rapid cycle operations, bucket suction, or other unfavorable conditions which may require smaller buckets for most efficient operation.
4. Weight of bucket plus load, must not exceed these capacities.
5. Dragline operation is not recommended with boom angles less than 35°.
6. Boom length for dragline/clamshell attachment operation should not exceed 80 ft..
7. Retractable high gantry must be pinned in the raised position for all capacities on the “Duty Cycle Capacities – Tube Boom” chart.
8. These capacities apply to the crane as originally manufactured and normally equipped by Link-Belt Construction Equipment Company.

**DUTY CYCLE CAPACITIES – TUBE BOOM**

Boom Length (ft)	Load Radius (ft)	Boom Angle (deg)	Side Frames Extended “A” Counterweight (All capacities listed are in pounds)	
			Dragline	Clamshell / Magnet “A” cwt
40	11	80.8	---	20,600
40	12	79.3	---	20,600
40	13	77.9	---	20,600
40	14	76.4	---	20,600
40	15	74.9	---	20,600
40	16	73.4	---	20,600
40	17	71.9	---	20,600
40	18	70.4	---	20,600
40	19	68.9	---	20,600
40	20	67.3	---	20,600
40	25	59.3	20,600	20,600
40	30	50.6	20,600	20,600
40	35	40.5	20,600	20,600
40	40	27.7	---	20,600
50	12	81.5	---	20,600
50	13	80.3	---	20,600
50	14	79.2	---	20,600
50	15	78.0	---	20,600
50	16	76.8	---	20,600
50	17	75.6	---	20,600
50	18	74.4	---	20,600
50	19	73.3	---	20,600
50	20	72.1	---	20,600
50	25	65.9	---	20,600
50	30	59.5	20,600	20,600
50	35	52.5	20,600	20,600
50	40	44.9	20,600	20,600
50	50	24.8	---	20,600
60	13	81.9	---	20,600
60	14	81.0	---	20,600
60	15	80.0	---	20,600
60	16	79.0	---	20,600
60	17	78.1	---	20,600
60	18	77.1	---	20,600

Boom Length (ft)	Load Radius (ft)	Boom Angle (deg)	Side Frames Extended “A” Counterweight (All capacities listed are in pounds)	
			Dragline	Clamshell / Magnet “A” cwt
60	19	76.1	---	20,600
60	20	75.1	---	20,600
60	25	70.1	---	20,600
60	30	64.9	---	20,600
60	35	59.6	20,600	20,600
60	40	53.8	20,600	20,600
60	50	40.8	20,600	20,600
60	60	22.6	---	16,470
70	15	81.5	---	20,600
70	16	80.6	---	20,600
70	17	79.8	---	20,600
70	18	79.0	---	20,600
70	19	78.1	---	20,600
70	20	77.3	---	20,600
70	25	73.1	---	20,600
70	30	68.7	---	20,600
70	35	64.3	---	20,600
70	40	59.6	20,600	20,600
70	50	49.6	20,600	20,600
70	60	37.7	18,300	16,470
70	70	20.9	---	13,140
80	16	81.8	---	20,600
80	17	81.1	---	20,600
80	18	80.4	---	20,600
80	19	79.6	---	20,600
80	20	78.9	---	20,600
80	25	75.2	---	20,600
80	30	71.5	---	20,600
80	35	67.7	---	20,600
80	40	63.7	---	20,600
80	50	55.4	20,600	20,600
80	60	46.2	18,300	16,470
80	70	35.2	14,600	13,140
80	80	19.5	---	10,710

# WORKING RANGE DIAGRAM

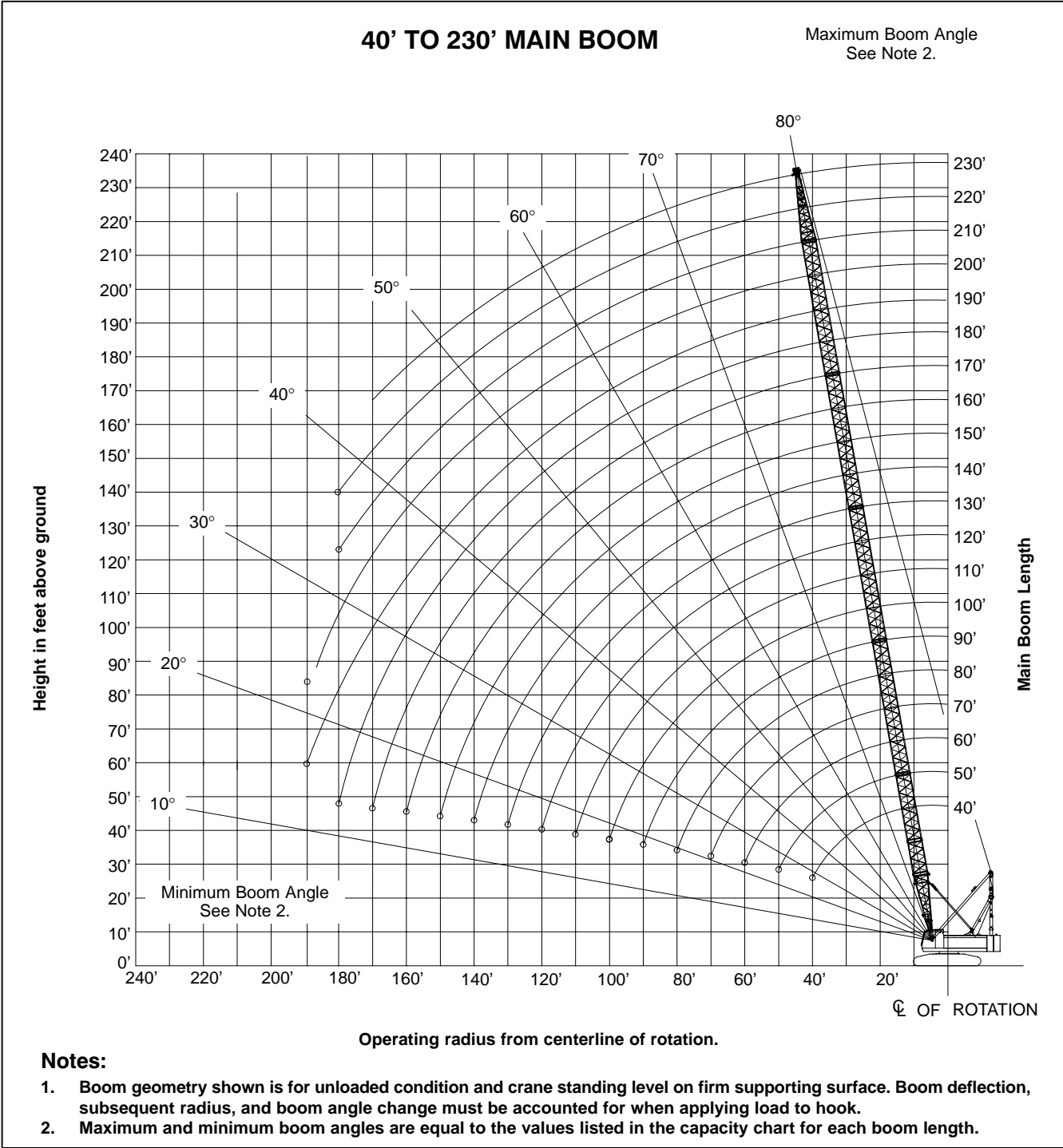

## CAPACITY DEDUCTIONS FOR LIFTING OFF MAIN BOOM HOOK WITH JIB INSTALLED

When using main boom hook, while jib is attached, reduce boom capacities by the values in the following chart:

Jib Length (ft)	Capacity Deduction (lb)
30	2,000
45	2,400
60	3,200
75	4,200

## CAPACITY DEDUCTIONS FOR LIFTING OFF MAIN BOOM HOOK WITH 5' TIP EXTENSION OR PILE DRIVER LEAD ADAPTER INSTALLED

When using main boom hook, while 5' tip extension or pile driver lead adapter is attached, reduce boom capacities by the values in the following chart:

Extension/Adapter	Capacity Deduction (lb)
5' Tip	700
Pile Driver Lead Adapter	200

## MAXIMUM ALLOWABLE CAPACITIES FOR 5' TIP EXTENSION

LIFTING CAPACITY TO BE THE SMALLEST OF THE FOLLOWING VALUES:

- 18,000 lb
- The standard crane lift capacity minus 700 lb for the crane configuration in use.

### NOTES:

- All notes are to be adhered to as listed on the standard lift crane capacity charts.
- Reduce the main boom lift capacities by 700 lb when the tip extension is installed.
- The maximum boom length on which the tip extension can be installed is 190 ft.
- Do not lift or suspend a load from the boom tip extension and main boom at the same time.

## MAXIMUM ALLOWABLE CAPACITIES FOR PILE DRIVER LEAD ADAPTER

LIFTING CAPACITY TO BE THE SMALLEST OF THE FOLLOWING VALUES:

- 70,000 lb
- The standard crane lift capacity minus 200 lb for crane configuration in use.

### NOTES:

- All notes are to be adhered to as listed on the standard lift crane capacity charts.
- Reduce the main boom lift capacities by 200 lb when the pile driver lead adapter is installed.
- The maximum boom length on which the pile driver lead adapter can be installed is 190 ft.

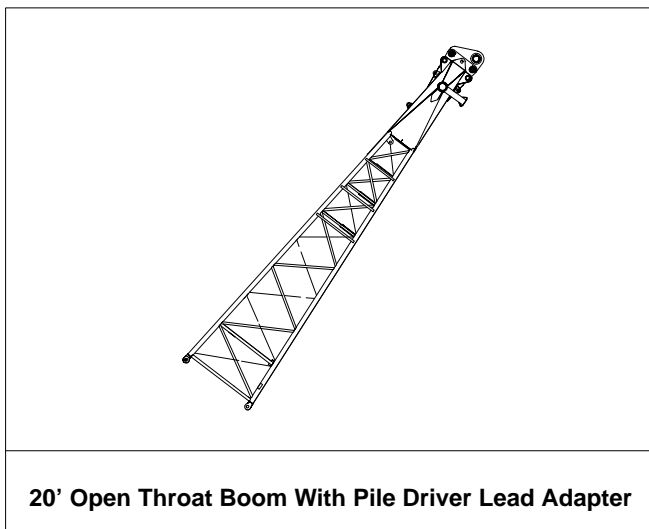

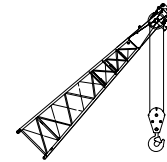
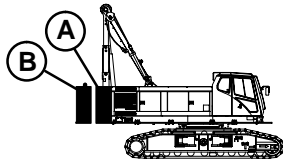

**Note: Refer To Page 8 For “Capacity Deductions” Caused By Any Attachment At The Boom Tip.**

MAIN BOOM CAPACITIES – 40 FT OPEN THROAT TUBE BOOM							
Load Radius (ft)	Boom Angle (deg)	Over End Blocked	360° Rotation				
			Side Frames Extended			Side Frames Retracted	
			AB CTWT (lb)	CTWT (lb)	A CTWT (lb)	0 CTWT (lb)	A CTWT (lb)
10.16	82.0	220,000	220,000	212,900	193,400	160,600	98,100
11	80.8	220,000	220,000	198,100	179,800	138,700	84,600
12	79.3	204,000	204,000	182,800	166,100	119,200	72,500
13	77.9	189,500	189,500	169,700	135,900	104,400	63,300
14	76.4	176,800	176,800	158,300	114,800	92,800	56,100
15	74.9	165,700	165,700	148,400	99,200	83,400	50,300
16	73.4	155,900	155,900	132,800	87,300	75,700	45,500
17	71.9	147,100	147,100	118,600	77,800	69,300	41,500
18	70.4	139,300	139,300	107,100	70,100	63,800	38,100
19	68.9	132,200	132,200	97,500	63,800	59,000	35,200
20	67.3	125,800	121,800	89,500	58,400	54,900	32,600
25	59.3	101,000	86,200	63,000	40,700	40,400	23,600
30	50.6	79,600	66,300	48,100	30,800	31,600	18,100
35	40.5	63,600	53,600	38,600	24,500	25,700	14,400
40	27.7	52,700	44,700	32,000	20,100	21,400	11,700

MAIN BOOM CAPACITIES – 70 FT OPEN THROAT TUBE BOOM							
Load Radius (ft)	Boom Angle (deg)	Over End Blocked	360° Rotation				
			Side Frames Extended			Side Frames Retracted	
			AB CTWT (lb)	CTWT (lb)	A CTWT (lb)	0 CTWT (lb)	A CTWT (lb)
14.34	82.0	160,600	160,600	154,000	110,300	90,000	54,500
15	81.5	160,600	160,600	147,600	100,300	83,900	50,800
16	80.6	155,100	155,100	133,800	88,200	76,100	45,900
17	79.8	146,400	146,400	119,500	78,700	69,600	41,900
18	79.0	138,600	138,600	107,800	70,900	64,100	38,400
19	78.1	131,600	131,600	98,200	64,400	59,300	35,400
20	77.3	125,300	122,400	90,100	59,000	55,200	32,900
25	73.1	100,700	86,600	63,400	41,100	40,600	23,800
30	68.7	80,000	66,600	48,400	31,100	31,700	18,200
35	64.3	63,900	53,800	38,900	24,800	25,800	14,500
40	59.6	53,000	45,000	32,300	20,300	21,600	11,900
50	49.6	39,200	33,500	23,700	14,600	15,800	8,300
60	37.7	30,700	26,300	18,300	11,000	12,200	6,000
70	20.9	24,900	21,400	14,600	8,500	9,600	4,300

MAIN BOOM CAPACITIES – 50 FT OPEN THROAT TUBE BOOM							
Load Radius (ft)	Boom Angle (deg)	Over End Blocked	360° Rotation				
			Side Frames Extended			Side Frames Retracted	
			AB CTWT (lb)	CTWT (lb)	A CTWT (lb)	0 CTWT (lb)	A CTWT (lb)
11.55	82.0	193,900	193,900	189,100	171,700	127,700	77,900
12	81.5	193,900	193,900	182,600	165,800	119,700	72,900
13	80.3	189,200	189,200	169,500	136,600	104,800	63,700
14	79.2	176,600	176,600	158,200	115,400	93,100	56,400
15	78.0	165,500	165,500	148,200	99,800	83,700	50,600
16	76.8	155,700	155,700	133,300	87,800	76,000	45,800
17	75.6	147,000	147,000	119,100	78,300	69,500	41,800
18	74.4	139,200	139,200	107,500	70,500	64,000	38,300
19	73.3	132,100	132,100	97,900	64,100	59,300	35,400
20	72.1	125,700	122,200	89,800	58,800	55,100	32,800
25	65.9	101,000	86,500	63,200	41,000	40,600	23,800
30	59.5	79,800	66,500	48,400	31,100	31,800	18,300
35	52.5	63,800	53,800	38,900	24,700	25,900	14,600
40	44.9	53,000	44,900	32,300	20,300	21,600	11,900
50	24.8	39,100	33,400	23,600	14,500	15,800	8,300

MAIN BOOM CAPACITIES – 80 FT OPEN THROAT TUBE BOOM							
Load Radius (ft)	Boom Angle (deg)	Over End Blocked	360° Rotation				
			Side Frames Extended			Side Frames Retracted	
			AB CTWT (lb)	CTWT (lb)	A CTWT (lb)	0 CTWT (lb)	A CTWT (lb)
15.73	82.0	136,200	136,200	136,200	91,400	78,100	47,100
16	81.8	136,200	136,200	133,900	88,300	76,100	45,900
17	81.1	136,200	136,200	119,500	78,700	69,600	41,800
18	80.4	134,500	134,500	107,900	70,900	64,000	38,300
19	79.6	131,300	131,300	98,200	64,500	59,300	35,400
20	78.9	125,000	122,400	90,100	59,000	55,100	32,800
25	75.2	100,500	86,600	63,300	41,100	40,500	23,700
30	71.5	80,000	66,500	48,400	31,100	31,700	18,100
35	67.7	63,900	53,800	38,800	24,700	25,700	14,400
40	63.7	53,000	44,900	32,200	20,300	21,500	11,800
50	55.4	39,100	33,400	23,600	14,500	15,700	8,200
60	46.2	30,600	26,200	18,300	10,900	12,100	5,900
70	35.2	24,900	21,300	14,600	8,400	9,500	4,300
80	19.5	20,700	17,800	11,900	6,800	7,600	3,000

MAIN BOOM CAPACITIES – 60 FT OPEN THROAT TUBE BOOM							
Load Radius (ft)	Boom Angle (deg)	Over End Blocked	360° Rotation				
			Side Frames Extended			Side Frames Retracted	
			AB CTWT (lb)	CTWT (lb)	A CTWT (lb)	0 CTWT (lb)	A CTWT (lb)
12.94	82.0	176,600	176,600	169,800	138,600	105,700	64,300
13	81.9	176,600	176,600	169,100	137,100	105,000	63,900
14	81.0	176,200	176,200	157,900	115,800	93,300	56,600
15	80.0	165,200	165,200	147,900	100,100	83,900	50,700
16	79.0	155,500	155,500	133,600	88,100	76,100	45,900
17	78.1	146,800	146,800	119,300	78,500	69,600	41,800
18	77.1	139,000	139,000	107,700	70,800	64,100	38,400
19	76.1	131,900	131,900	98,100	64,300	59,300	35,400
20	75.1	125,600	122,300	90,000	58,900	55,200	32,900
25	70.1	100,900	86,600	63,300	41,100	40,600	23,800
30	64.9	80,000	66,600	48,400	31,100	31,800	18,300
35	59.6	63,900	53,800	38,900	24,800	25,900	14,600
40	53.8	53,000	45,000	32,300	20,400	21,600	11,900
50	40.8	39,200	33,500	23,700	14,600	15,900	8,300
60	22.6	30,700	26,300	18,300	11,000	12,200	6,000

MAIN BOOM CAPACITIES – 90 FT OPEN THROAT TUBE BOOM							
Load Radius (ft)	Boom Angle (deg)	Over End Blocked	360° Rotation				
			Side Frames Extended			Side Frames Retracted	
			AB CTWT (lb)	CTWT (lb)	A CTWT (lb)	0 CTWT (lb)	A CTWT (lb)
17.12	82.0	124,400	124,400	118,100	77,800	68,800	41,300
18	81.4	122,800	122,800	107,900	71,000	64,000	38,300
19	80.8	122,800	122,800	98,200	64,500	59,200	35,300
20	80.1	122,800	122,400	90,100	59,000	55,000	32,700
25	76.9	100,200	86,500	63,300	41,100	40,400	23,600
30	73.6	79,900	66,500	48,300	31,000	31,500	18,000
35	70.3	63,800	53,700	38,700	24,600	25,600	14,300
40	66.8	52,900	44,800	32,100	20,200	21,300	11,600
50	59.7	39,000	33,300	23,500	14,400	15,600	8,100
60	52.0	30,500	26,100	18,200	10,800	11,900	5,800
70	43.4	24,800	21,200	14,500	8,300	9,400	4,100
80	33.1	20,700	17,700	11,800	6,500	7,500	2,900
90	18.4	17,500	14,900	9,800	5,100	6,000	2,000

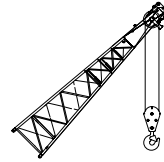
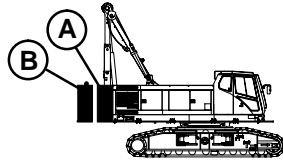

MAIN BOOM CAPACITIES – 100 FT OPEN THROAT TUBE BOOM									
Load Radius (ft)	Boom Angle (deg)	Over End Blocked	360° Rotation					PROHIBITED	
			Side Frames Extended				Side Frames Retracted		
			AB CTWT (lb)	AB CTWT (lb)	A CTWT (lb)	0 CTWT (lb)	A CTWT (lb)		0 CTWT (lb)
18.51	82.0	111,900	111,900	102,700	67,500	61,300			
19	81.7	110,500	110,500	98,200	64,500	59,100			
20	81.1	110,500	110,500	90,100	59,000	54,900			
25	78.2	99,900	86,400	63,200	41,000	40,300			
30	75.3	79,800	66,400	48,200	30,900	31,400			
35	72.3	63,700	53,600	38,600	24,500	25,400			
40	69.3	52,800	44,700	32,000	20,000	21,200			
50	63.0	38,900	33,100	23,400	14,200	15,400			
60	56.4	30,400	26,000	18,000	10,600	11,800			
70	49.2	24,700	21,100	14,400	8,200	9,200			
80	41.1	20,500	17,600	11,700	6,400	7,300			
90	31.3	17,400	14,800	9,700	5,000	5,900			
100	17.4	15,000	12,700	8,000	3,900	4,700			

MAIN BOOM CAPACITIES – 130 FT OPEN THROAT TUBE BOOM									
Load Radius (ft)	Boom Angle (deg)	Over End Blocked	360° Rotation					PROHIBITED	
			Side Frames Extended				Side Frames Retracted		
			AB CTWT (lb)	AB CTWT (lb)	A CTWT (lb)	0 CTWT (lb)	A CTWT (lb)		0 CTWT (lb)
22.69	82.0	82,700	82,700	73,200	47,600	45,600			
25	81.0	81,700	81,700	62,900	40,700	39,800			
30	78.7	79,500	66,000	47,800	30,500	30,900			
35	76.5	63,400	53,100	38,200	24,100	24,900			
40	74.2	52,400	44,200	31,500	19,600	20,700			
50	69.6	38,400	32,700	22,900	13,800	14,900			
60	64.8	29,900	25,500	17,500	10,200	11,200			
70	59.8	24,200	20,600	13,900	7,700	8,700			
80	54.5	20,100	17,100	11,200	5,900	6,800			
90	48.9	17,000	14,400	9,200	4,500	5,400			
100	42.8	14,500	12,200	7,600	3,500	4,200			
110	35.8	12,600	10,500	6,300	2,600	3,300			
120	27.4	10,900	9,100	5,200	—	2,500			
130	15.3	9,600	7,900	4,300	—	—			

MAIN BOOM CAPACITIES – 110 FT OPEN THROAT TUBE BOOM								
Load Radius (ft)	Boom Angle (deg)	Over End Blocked	360° Rotation				PROHIBITED	
			Side Frames Extended			Side Frames Retracted		
			AB CTWT (lb)	AB CTWT (lb)	A CTWT (lb)	0 CTWT (lb)		A CTWT (lb)
19.9	82.0	100,800	100,800	90,800	59,400	55,200		
20	81.9	100,800	100,800	90,000	58,900	54,800		
25	79.3	98,300	86,300	63,100	40,900	40,100		
30	76.6	79,700	66,200	48,100	30,800	31,200		
35	74.0	63,600	53,400	38,500	24,400	25,300		
40	71.2	52,700	44,500	31,800	19,900	21,000		
50	65.6	38,700	33,000	23,200	14,100	15,300		
60	59.8	30,200	25,800	17,900	10,500	11,600		
70	53.5	24,500	20,900	14,200	8,000	9,100		
80	46.7	20,400	17,400	11,500	6,200	7,200		
90	39.1	17,300	14,700	9,500	4,900	5,700		
100	29.8	14,800	12,600	7,900	3,800	4,600		
110	16.6	12,900	10,800	6,600	2,900	3,600		

MAIN BOOM CAPACITIES – 140 FT OPEN THROAT TUBE BOOM									
Load Radius (ft)	Boom Angle (deg)	Over End Blocked	360° Rotation					PROHIBITED	
			Side Frames Extended				Side Frames Retracted		
			AB CTWT (lb)	AB CTWT (lb)	A CTWT (lb)	0 CTWT (lb)	A CTWT (lb)		0 CTWT (lb)
24.08	82.0	75,300	75,300	66,500	—	—			
25	81.6	75,300	75,300	62,800	—	—			
30	79.5	73,400	65,800	47,700	—	—			
35	77.5	63,200	53,000	38,100	—	—			
40	75.4	52,200	44,100	31,400	—	—			
50	71.1	38,300	32,500	22,700	—	—			
60	66.7	29,800	25,300	17,300	—	—			
70	62.1	24,000	20,400	13,700	—	—			
80	57.4	19,900	16,900	11,000	—	—			
90	52.4	16,800	14,200	9,000	—	—			
100	47.0	14,300	12,100	7,400	—	—			
110	41.2	12,400	10,400	6,100	—	—			
120	34.5	10,800	8,900	5,100	—	—			
130	26.4	9,400	7,800	4,200	—	—			
140	14.7	8,200	6,700	3,400	—	—			

MAIN BOOM CAPACITIES – 120 FT OPEN THROAT TUBE BOOM									
Load Radius (ft)	Boom Angle (deg)	Over End Blocked	360° Rotation					PROHIBITED	
			Side Frames Extended				Side Frames Retracted		
			AB CTWT (lb)	AB CTWT (lb)	A CTWT (lb)	0 CTWT (lb)	A CTWT (lb)		0 CTWT (lb)
21.29	82.0	92,000	92,000	81,100	52,900	50,000			
25	80.2	89,700	86,200	63,000	40,800	40,000			
30	77.8	79,600	66,100	48,000	30,700	31,100			
35	75.3	63,500	53,300	38,400	24,200	25,100			
40	72.8	52,500	44,400	31,700	19,700	20,800			
50	67.8	38,600	32,800	23,100	13,900	15,100			
60	62.5	30,100	25,700	17,700	10,300	11,400			
70	57.0	24,400	20,800	14,000	7,900	8,900			
80	51.1	20,200	17,200	11,400	6,100	7,000			
90	44.6	17,100	14,500	9,400	4,700	5,600			
100	37.3	14,700	12,400	7,800	3,600	4,400			
110	28.6	12,700	10,700	6,500	2,700	3,500			
120	15.9	11,100	9,300	5,400	2,000	2,700			

MAIN BOOM CAPACITIES – 150 FT OPEN THROAT TUBE BOOM									
Load Radius (ft)	Boom Angle (deg)	Over End Blocked	360° Rotation					PROHIBITED	
			Side Frames Extended				Side Frames Retracted		
			AB CTWT (lb)	AB CTWT (lb)	A CTWT (lb)	0 CTWT (lb)	A CTWT (lb)		0 CTWT (lb)
25.47	82.0	69,000	69,000	60,900	—	—			
30	80.2	67,300	65,700	47,500	—	—			
35	78.3	63,100	52,800	37,900	—	—			
40	76.3	52,100	43,900	31,200	—	—			
50	72.4	38,100	32,300	22,500	—	—			
60	68.3	29,600	25,100	17,200	—	—			
70	64.1	23,800	20,200	13,500	—	—			
80	59.8	19,700	16,700	10,800	—	—			
90	55.3	16,600	14,000	8,800	—	—			
100	50.5	14,200	11,900	7,200	—	—			
110	45.4	12,200	10,200	5,900	—	—			
120	39.7	10,600	8,800	4,900	—	—			
130	33.3	9,200	7,600	4,000	—	—			
140	25.5	8,100	6,600	3,200	—	—			
150	14.2	7,100	5,700	2,500	—	—			

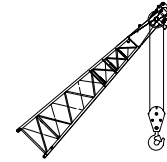
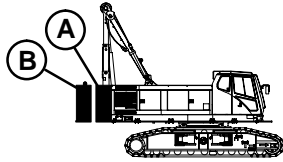

MAIN BOOM CAPACITIES – 160 FT OPEN THROAT TUBE BOOM							
Load Radius (ft)	Boom Angle (deg)	Over End Blocked	360° Rotation				
			Side Frames Extended			Side Frames Retracted	
			AB CTWT (lb)	AB CTWT (lb)	A CTWT (lb)	0 CTWT (lb)	A CTWT (lb)
26.86	82.0	63,100	63,100	56,000	PROHIBITED		
30	80.9	62,300	62,300	47,400			
35	79.0	60,700	52,700	37,700			
40	77.2	51,900	43,700	31,000			
50	73.5	37,900	32,100	22,400			
60	69.7	29,400	24,900	17,000			
70	65.9	23,700	20,000	13,300			
80	61.9	19,500	16,500	10,600			
90	57.7	16,400	13,800	8,600			
100	53.4	14,000	11,700	7,000			
110	48.8	12,000	10,000	5,700			
120	43.8	10,400	8,600	4,700			
130	38.4	9,100	7,400	3,800			
140	32.2	7,900	6,400	3,000			
150	24.7	6,900	5,500	2,400			
160	13.8	6,000	4,700	—			

MAIN BOOM CAPACITIES – 180 FT OPEN THROAT TUBE BOOM							
Load Radius (ft)	Boom Angle (deg)	Over End Blocked	360° Rotation				
			Side Frames Extended			Side Frames Retracted	
			AB CTWT (lb)	AB CTWT (lb)	A CTWT (lb)	0 CTWT (lb)	A CTWT (lb)
29.64	82.0	52,200	52,200	PROHIBITED			
30	81.9	51,800	51,800				
35	80.3	50,500	50,500				
40	78.7	49,300	43,400				
50	75.4	37,600	31,800				
60	72.1	29,000	24,600				
70	68.7	23,300	19,700				
80	65.2	19,100	16,100				
90	61.7	16,000	13,400				
100	58.0	13,600	11,300				
110	54.2	11,600	9,600				
120	50.1	10,000	8,200				
130	45.8	8,700	7,000				
140	41.2	7,500	6,000				
150	36.1	6,500	5,100				
160	30.3	5,700	4,400				
170	23.2	4,900	3,700				
180	13.0	4,200	3,100				

MAIN BOOM CAPACITIES – 170 FT OPEN THROAT TUBE BOOM							
Load Radius (ft)	Boom Angle (deg)	Over End Blocked	360° Rotation				
			Side Frames Extended			Side Frames Retracted	
			AB CTWT (lb)	AB CTWT (lb)	A CTWT (lb)	0 CTWT (lb)	A CTWT (lb)
28.25	82.0	56,900	56,900	51,700	PROHIBITED		
30	81.4	56,100	56,100	47,200			
35	79.7	54,700	52,500	37,600			
40	78.0	51,800	43,600	30,900			
50	74.5	37,800	32,000	22,200			
60	71.0	29,200	24,800	16,800			
70	67.4	23,500	19,900	13,100			
80	63.7	19,300	16,300	10,400			
90	59.8	16,200	13,600	8,400			
100	55.9	13,800	11,500	6,800			
110	51.7	11,800	9,800	5,500			
120	47.2	10,200	8,400	4,500			
130	42.5	8,900	7,200	3,600			
140	37.2	7,700	6,200	2,800			
150	31.2	6,700	5,300	2,200			
160	23.9	5,900	4,500	—			
170	13.3	5,100	3,900	—			

MAIN BOOM CAPACITIES – 190 FT OPEN THROAT TUBE BOOM							
Load Radius (ft)	Boom Angle (deg)	Over End Blocked	360° Rotation				
			Side Frames Extended			Side Frames Retracted	
			AB CTWT (lb)	AB CTWT (lb)	A CTWT (lb)	0 CTWT (lb)	A CTWT (lb)
31.04	82.0	47,700	47,700	PROHIBITED			
35	80.8	46,500	46,500				
40	79.3	45,300	43,200				
50	76.2	37,400	31,600				
60	73.0	28,900	24,400				
70	69.9	23,100	19,500				
80	66.6	18,900	15,900				
90	63.3	15,800	13,200				
100	59.9	13,400	11,100				
110	56.3	11,400	9,400				
120	52.6	9,800	8,000				
130	48.7	8,500	6,800				
140	44.5	7,300	5,800				
150	40.1	6,300	4,900				
160	35.1	5,500	4,100				
170	29.5	4,700	3,500				
180	22.6	4,000	2,900				
190	12.6	3,400	2,300				

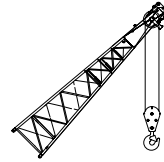
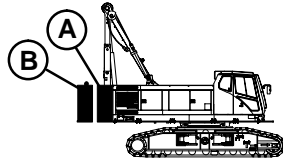

MAIN BOOM CAPACITIES – 200 FT OPEN THROAT TUBE BOOM							
Load Radius (ft)	Boom Angle (deg)	Over End Blocked	360° Rotation				
			Side Frames Extended			Side Frames Retracted	
			AB CTWT (lb)	AB CTWT (lb)	A CTWT (lb)	0 CTWT (lb)	A CTWT (lb)
32.43	82.0	43,400	43,400				
35	81.3	42,900	42,900				
40	79.8	41,800	41,800				
50	76.9	37,200	31,400				
60	73.9	28,700	24,200				
70	70.9	22,900	19,300				
80	67.8	18,700	15,700				
90	64.7	15,600	13,000				
100	61.5	13,200	10,900				
110	58.2	11,200	9,200				
120	54.8	9,600	7,700				
130	51.2	8,300	6,600				
140	47.4	7,100	5,600				
150	43.4	6,100	4,700				
160	39.0	5,300	3,900				
170	34.2	4,500	3,300				
180	28.7	3,800	2,700				
190	22.0	3,200	2,200				
200	12.3	2,700	—				
PROHIBITED							

MAIN BOOM CAPACITIES – 220 FT OPEN THROAT TUBE BOOM							
Load Radius (ft)	Boom Angle (deg)	Over End Blocked	360° Rotation				
			Side Frames Extended			Side Frames Retracted	
			AB CTWT (lb)	AB CTWT (lb)	A CTWT (lb)	0 CTWT (lb)	A CTWT (lb)
35.21	82.0	35,100	35,100				
40	80.7	34,600	34,600				
50	78.1	33,300	31,000				
60	75.4	28,300	23,700				
70	72.7	22,500	18,800				
80	70.0	18,300	15,300				
90	67.2	15,200	12,500				
100	64.3	12,700	10,400				
110	61.4	10,800	8,700				
120	58.4	9,200	7,300				
130	55.2	7,800	6,100				
140	52.0	6,700	5,100				
150	48.6	5,700	4,300				
160	45.1	4,800	3,500				
170	41.2	4,000	2,800				
180	37.1	3,100	2,200				
190	32.6	2,200	—				
200	27.4	—	—				
210	21.0	—	—				
220	11.7	—	—				
PROHIBITED							

MAIN BOOM CAPACITIES – 210 FT OPEN THROAT TUBE BOOM							
Load Radius (ft)	Boom Angle (deg)	Over End Blocked	360° Rotation				
			Side Frames Extended			Side Frames Retracted	
			AB CTWT (lb)	AB CTWT (lb)	A CTWT (lb)	0 CTWT (lb)	A CTWT (lb)
33.82	82.0	39,300	39,300				
35	81.7	39,300	39,300				
40	80.3	38,900	38,900				
50	77.5	36,700	31,200				
60	74.7	28,400	23,900				
70	71.9	22,700	19,000				
80	69.0	18,500	15,500				
90	66.0	15,400	12,800				
100	63.0	12,900	10,600				
110	59.9	11,000	8,900				
120	56.7	9,400	7,500				
130	53.3	8,000	6,300				
140	49.8	6,900	5,300				
150	46.2	5,900	4,500				
160	42.3	5,000	3,700				
170	38.0	4,300	3,000				
180	33.4	3,600	2,500				
190	28.0	3,000	—				
200	21.5	2,500	—				
210	12.0	—	—				
PROHIBITED							

MAIN BOOM CAPACITIES – 230 FT OPEN THROAT TUBE BOOM							
Load Radius (ft)	Boom Angle (deg)	Over End Blocked	360° Rotation				
			Side Frames Extended			Side Frames Retracted	
			AB CTWT (lb)	AB CTWT (lb)	A CTWT (lb)	0 CTWT (lb)	A CTWT (lb)
36.6	82.0	31,300	31,300				
40	81.1	31,100	31,100				
50	78.6	29,900	29,900				
60	76.1	25,300	23,500				
70	73.5	21,700	18,600				
80	70.9	18,100	15,000				
90	68.2	15,000	12,300				
100	65.5	12,500	10,200				
110	62.7	10,600	8,500				
120	59.9	8,900	7,100				
130	57.0	7,600	5,900				
140	53.9	6,200	4,900				
150	50.8	4,900	4,000				
160	47.5	3,800	3,300				
170	44.0	2,700	2,600				
180	40.3	—	—				
190	36.3	—	—				
200	31.8	—	—				
210	26.7	—	—				
220	20.5	—	—				
230	11.5	—	—				
PROHIBITED							